



Trinity College

WA Exams Practice Paper A, 2016

Question/Answer Booklet

MATHEMATICS APPLICATIONS UNITS 3 AND 4 Section Two: Calculator-assumed

If required by your examination administrator, please place your student identification label in this box

Student Number: In figures

--	--	--	--	--	--	--	--

In words

Your name

Time allowed for this section

Reading time before commencing work: ten minutes

Working time for section: one hundred minutes

Materials required/recommended for this section

To be provided by the supervisor

This Question/Answer Booklet

Formula Sheet (retained from Section One)

To be provided by the candidate

Standard items: pens (blue/black preferred), pencils (including coloured), sharpener, correction fluid/tape, eraser, ruler, highlighters

Special items: drawing instruments, templates, notes on two unfolded sheets of A4 paper, and up to three calculators approved for use in the WACE examinations

Important note to candidates

No other items may be taken into the examination room. It is **your** responsibility to ensure that you do not have any unauthorised notes or other items of a non-personal nature in the examination room. If you have any unauthorised material with you, hand it to the supervisor **before** reading any further.

Structure of this paper

Section	Number of questions available	Number of questions to be answered	Working time (minutes)	Marks available	Percentage of exam
Section One: Calculator-free	8	8	50	51	35
Section Two: Calculator-assumed	12	12	100	100	65
Total				151	100

Instructions to candidates

1. The rules for the conduct of examinations are detailed in the school handbook. Sitting this examination implies that you agree to abide by these rules.
2. Write your answers in this Question/Answer Booklet.
3. You must be careful to confine your response to the specific question asked and to follow any instructions that are specified to a particular question.
4. Spare pages are included at the end of this booklet. They can be used for planning your responses and/or as additional space if required to continue an answer.
 - Planning: If you use the spare pages for planning, indicate this clearly at the top of the page.
 - Continuing an answer: If you need to use the space to continue an answer, indicate in the original answer space where the answer is continued, i.e. give the page number. Fill in the number of the question that you are continuing to answer at the top of the page.
5. **Show all your working clearly.** Your working should be in sufficient detail to allow your answers to be checked readily and for marks to be awarded for reasoning. Incorrect answers given without supporting reasoning cannot be allocated any marks. For any question or part question worth more than two marks, valid working or justification is required to receive full marks. If you repeat any question, ensure that you cancel the answer you do not wish to have marked.
6. It is recommended that you **do not use pencil**, except in diagrams.
7. The Formula Sheet is **not** to be handed in with your Question/Answer Booklet.

Section Two: Calculator-assumed

65% (100 Marks)

This section has **twelve (12)** questions. Answer **all** questions. Write your answers in the spaces provided.

Working time for this section is 100 minutes.

Question 9

(7 marks)

The project network below consists of 16 tasks, with completion times shown in days.

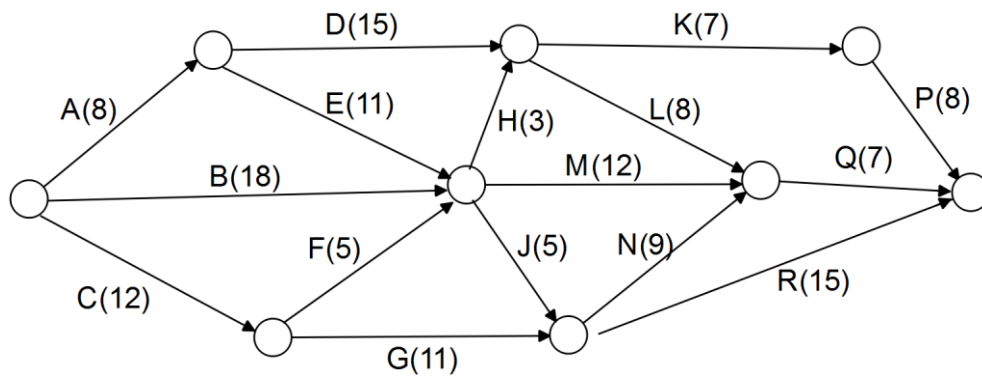

- (a) List, in order, the tasks on the critical path and determine the minimum completion time for this project. (3 marks)

- (b) The time to complete task F increases by four days. Determine the effect, if any, on your answers to part (a). (2 marks)

- (c) An additional task that is not a predecessor for any other task, is to be added to the network and can commence once task D is complete. How many days can this new task be allocated without increasing the minimum completion time? (2 marks)

Question 10

(9 marks)

A cycling event was open to teams consisting of one male and one female competitor. The scatterplot below shows the times, rounded to the nearest minute, taken by each pair of competitors in the event.

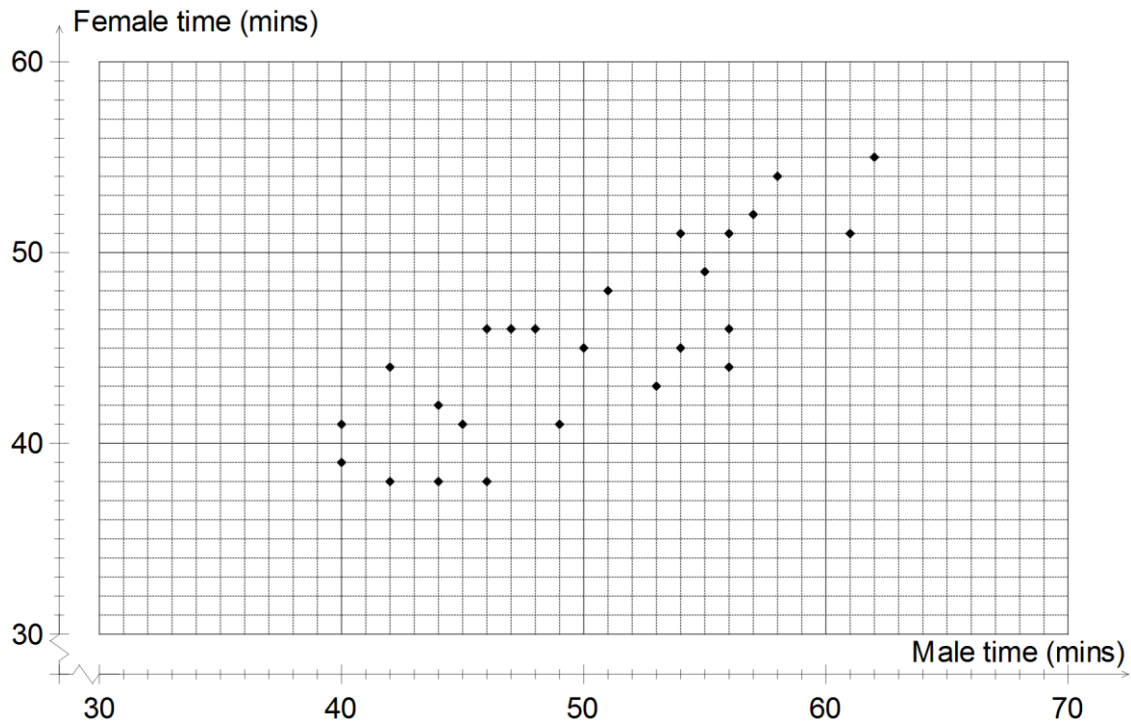

- (a) The male competitor in one team took 50 minutes. How long did his female team mate take? (1 mark)
- (b) How many teams had a total time of 110 minutes or more? (1 mark)
- (c) Describe a feature of the scatterplot that suggests the presence of an association between the two variables. (1 mark)

The correlation coefficient between the pairs of times is 0.86 and the equation of the least-squares line is $f = 0.635m + 13.55$, where f is the female time and m is the male time.

- (d) State which is the explanatory variable for this relationship. (1 mark)

- (e) What percentage of the variation in the female times can be explained by the variation in the male times? (1 mark)
- (f) Predict the time taken, to the nearest minute, by the female team mate of a male who took
- (i) 52 minutes (1 mark)
- (ii) 65 minutes (1 mark)
- (g) Which prediction in (f) do you consider to be the most reliable? Explain your answer. (2 marks)

Question 11

(7 marks)

- (a) Determine the exact value of T_7 for the following two sequences, one of which is arithmetic and the other is geometric.
- (i) 14, 17, 20, 23, 26, ... (1 mark)
- (ii) 500, 400, 320, 256, 204.8, ... (1 mark)
- (b) A sequence is given by $T_{n+1} = 5 - 2T_n$ $T_1 = 3$.
- (i) Calculate T_2 . (1 mark)
- (ii) What is the smallest value of n for which $T_n \geq 300$. (1 mark)
- (c) After clean-up operations began on a small oil slick, it was observed that the area of the slick decreased by 8% every hour. The initial area of the oil slick was 550m^2 .
- (i) What was the area of the slick 1 hour after clean-up began? (1 mark)
- (ii) Write a rule to determine A_n , the area of the slick n hours after clean-up operations began. (2 marks)

Question 12**(8 marks)**

A lump sum of money is invested in a savings fund that compounds interest annually.

The amount of money in the savings fund, T_n , is given by the recursive rule

$T_{n+1} = 1.05T_n$, $T_0 = 2250$, where n is the number of years after the initial deposit.

- (a) State the initial amount of the lump sum. (1 mark)
- (b) State the annual interest rate offered by the savings fund. (1 mark)
- (c) Determine
- (i) the amount of money, to the nearest cent, in the savings fund after four years. (2 marks)
- (ii) the amount of interest accumulated during the first four years. (1 mark)
- (d) Another savings fund was offering an interest rate of 4.9% pa compounded monthly. Would this fund be a better choice for savers investing the same amount for four years? Justify your answer. (3 marks)

Question 13

(8 marks)

The directed graph below shows the available conveyor belts to transport raw product from mine M to port P. The number on each edge is the maximum weight of raw product that can be moved along it, in hundreds of tonnes per hour.

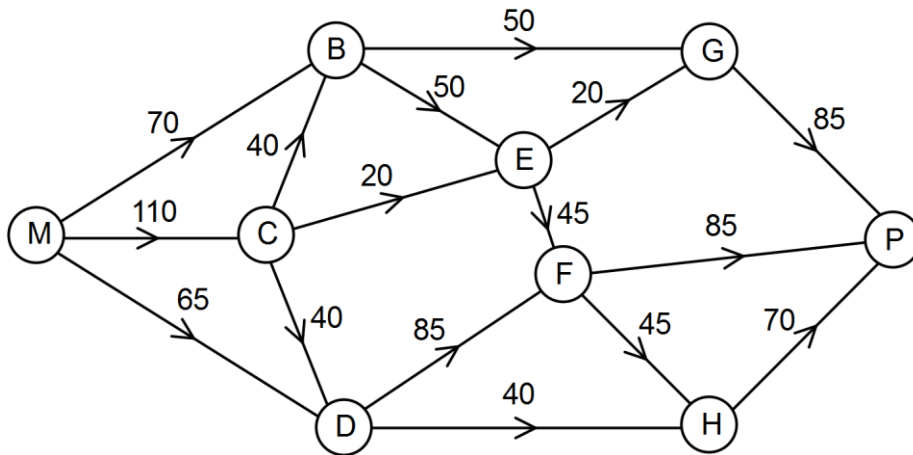

- (a) Determine the maximum weight of raw product that can be transported in one hour from the mine M to the port P. Show systematic working. (5 marks)

- (b) The mine transport manager has funds to increase the capacity of CB or CD by up to 3000 tonnes per hour. Determine which, if either, would be the best to choose and calculate the new maximum weight of raw product that can be transported in one hour from the mine M to the port P. Justify your answer. (3 marks)

A copy of the original directed graph is provided below for your use, if required.

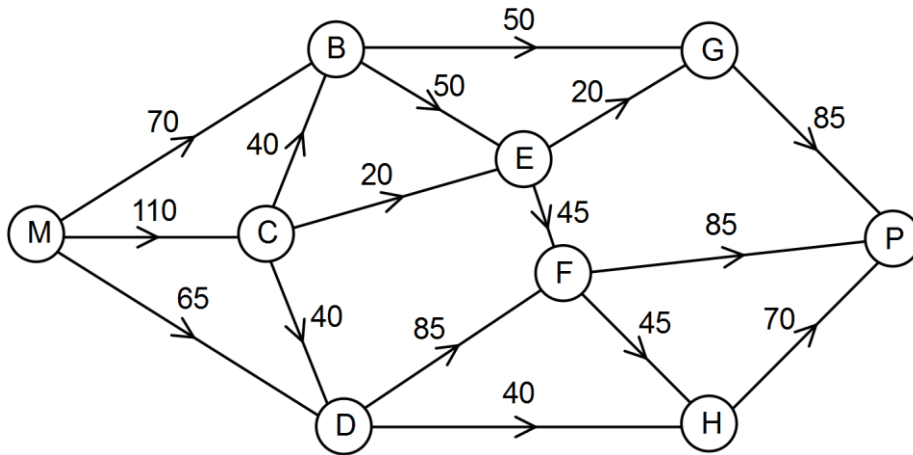

Question 14**(8 marks)**

The table below shows the responses of 120 students when asked which one of three school facilities they used most often during term time.

Facility	Age group	
	11 - 13 years	14 - 16 years
Gym	8	38
Library	11	22
Canteen	21	20

- (a) How many 14 - 16 year old responded? (1 mark)
- (b) What percentage of 11 - 13 year olds used the gym most often? (1 mark)
- (c) Construct an appropriately percentaged two-way table that can be used to help identify whether the use of a facility is associated with age group. (3 marks)
- (d) Does the use of a facility appear to be associated with age group? Justify your answer. (3 marks)

Question 15**(7 marks)**

(a) The size of a population of feral cats can be represented by the recurrence relation $p_{n+1} = 0.8p_n + 50$, $p_0 = 76$, where p_n is the size of the population after n months.

(i) Determine the size of the population after 1 month. (1 mark)

(ii) Determine the size of the population after 12 months. (1 mark)

(iii) Comment on the size of the cat population in the long term. (2 marks)

(b) Another population of 24 feral cats was observed to grow to 44 after one year and increase to 74 after two years. The size of this population can be represented by $p_{n+1} = r \times p_n + k$, $p_0 = a$, where p_n is the size of the population after n years.

Determine the values of r , k and a . (3 marks)

Question 16

(8 marks)

The average number of cigarettes smoked per week by Australian adults aged between 18 and 24 years is shown in the table below for a number of years.

Year (t)	1989	1992	1995	1998	2001	2004	2007	2010
Number smoked (n)	18.6	16.6	14.8	14.1	12.3	11.2	11.6	11.0

(a) Complete the scatterplot below.

(1 mark)

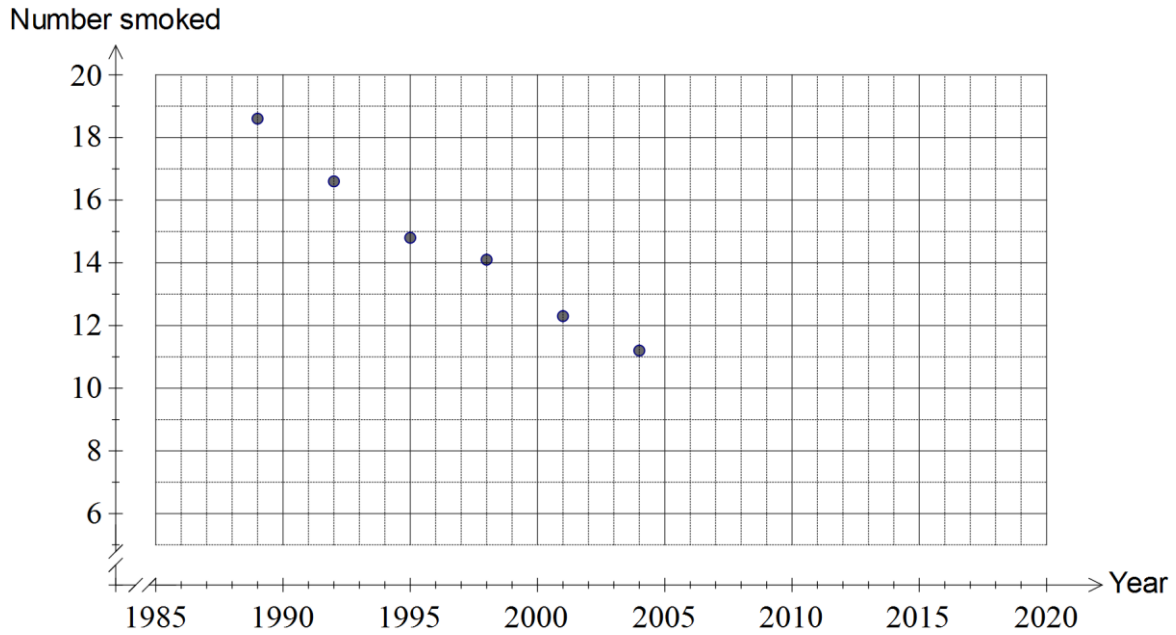

(b) Determine the correlation coefficient between t and n .

(1 mark)

(c) Describe the association between the variables in terms of direction and strength.

(2 marks)

(d) Determine the equation of the least-squares line in the form $n = at + b$.

(1 mark)

- (e) Interpret, in the context of this question, the value of the gradient of the least-squares line in (d). (1 mark)
- (f) Predict the average number of cigarettes that will be smoked per week by Australian adults aged between 18 and 24 years in 2016, explaining any dangers associated with your prediction. (2 marks)

Question 17

(7 marks)

- (a) A way to repay a loan of \$5 900 using monthly repayments of \$1 000 is shown in the table below. At the end of each month, interest of 1.5% of the amount owing at the start of the month is added to the loan and a repayment of \$1 000 is then subtracted. The final loan repayment, of less than \$1 000, brings the balance of the loan to zero.

Month	Balance at start of month	Interest	Repayment	Balance carried forward to start of next month
1	5 900.00	88.50	1 000.00	4 988.50
2	4 988.50	74.83	1 000.00	4 063.33
3	4 063.33	60.95	1 000.00	3 124.28
4	3 124.28	46.86	1 000.00	2 171.14
5	2 171.14	32.57	1 000.00	
6	A	B	1 000.00	C
7			D	0.00

Determine the values of A, B, C and D in the table above.

(4 marks)

- (b) A loan of \$5 250, with interest of 7.2% per annum compounded monthly, is to be repaid with equal monthly repayments over two and a half years.

(i) How many repayments are required? (1 mark)

(ii) Determine the amount of each repayment, rounding your answer to the nearest dollar. (2 marks)

Question 18

(7 marks)

The cost, in thousands of dollars, of installing underground power lines between various locations and a substation located at S is shown in the weighted graph below.

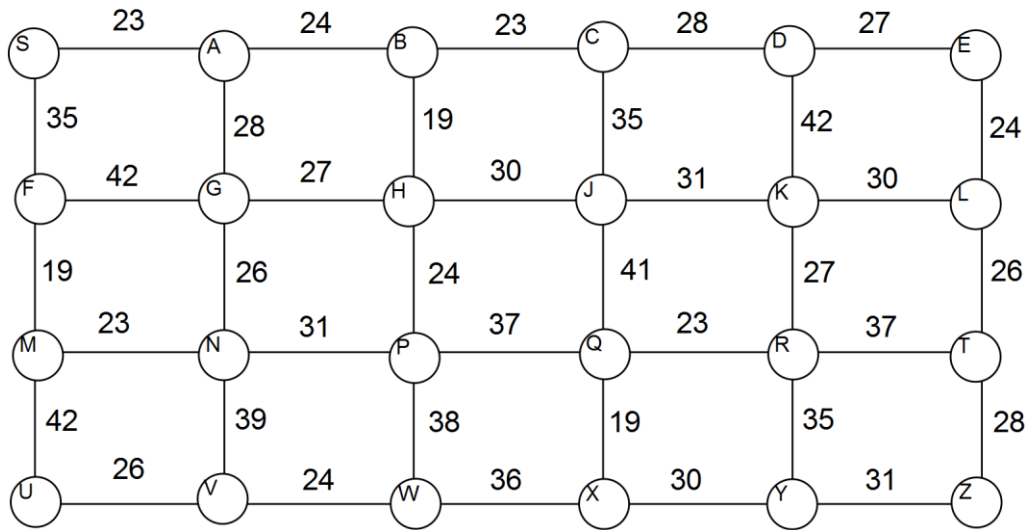

- (a) Identify the minimum spanning tree on the above graph. (3 marks)

- (b) What is the cost of installing underground power lines to all the locations, based on the minimum spanning tree? (2 marks)

- (c) If, for security reasons, power lines must be installed between S and F, F and M and M and U, determine what effect this has on the cost of installing underground power to all the locations. (2 marks)

Question 19

(16 marks)

The table below shows N , the number of calls per weekday to an enquiry centre, over a three-week period.

	Week 1					Week 2					Week 3				
Day	M	T	W	T	F	M	T	W	T	F	M	T	W	T	F
T	1	2	3	4	5	6	7	8	9	10	11	12	13	14	15
N	48	38	30	38	41	51	39	34	39	44	55	42	39	44	46

- (a) Construct a time series plot of this data on the axes below. (3 marks)

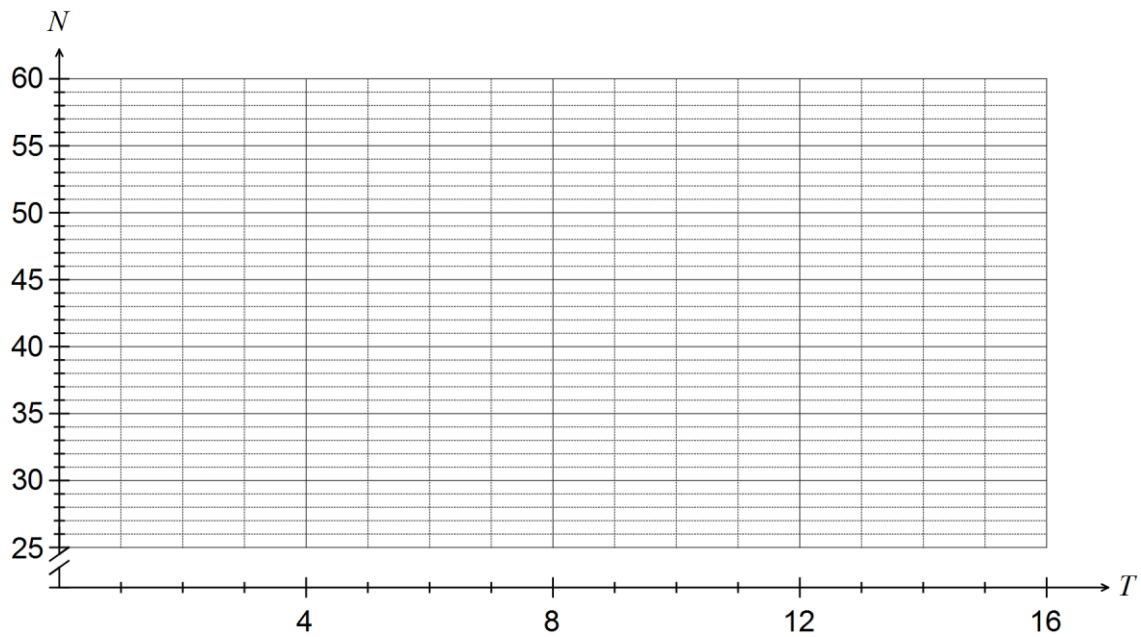

- (b) Comment on features of the above graph, including trend and seasonality. (2 marks)

- (c) What is noticeable about the number of calls to the enquiry line on Wednesdays? (1 mark)

- (d) Calculate the five-point moving average for Tuesday of Week 2. (1 mark)

The seasonal index for each weekday is shown in the table below.

Day	Mon	Tue	Wed	Thu	Fri
Seasonal index	1.23	0.95	0.82	0.96	1.04

This table shows the deseasonalised values of the number of calls per weekday, D .

	Week 1					Week 2					Week 3				
Day	M	T	W	T	F	M	T	W	T	F	M	T	W	T	F
T	1	2	3	4	5	6	7	8	9	10	11	12	13	14	15
D	39.1	40.1	36.7	39.4	39.3	41.6	41.1	41.6	40.5	42.1	44.8	44.3	47.7	A	B

(e) Calculate the values of A and B in the table above. (2 marks)

(f) Determine the equation of the least-squares regression line that can be used to predict D from time T . (2 marks)

(g) Draw the line of regression calculated in (f) on the graph in (a). (2 marks)

(h) Forecast the expected number of calls to the enquiry centre on Monday of Week 4. (3 marks)

Question 20**(8 marks)**

A lottery winner received a prize of \$760 000.

- (a) The winner used one-half of their winnings to set up an annuity so that they received a monthly payment of \$8 600. The annuity attracted interest of 8.4% per annum, compounded monthly.
- (i) Show that after the first payment, the annuity is worth \$374 060. (3 marks)
- (ii) What is the value of the annuity after the second payment has been made? (1 mark)
- (iii) To the nearest month, how long will the annuity last and how much will the winner have received in total from the annuity after the final payment of \$8 600? (2 marks)
- (b) If the winner had chosen to invest all their prize money in an annuity paying 0.7% per month, and did not want the value of the annuity to fall below \$760 000, determine the largest possible monthly payment. (2 marks)

End of questions

Additional working space

Question number: _____

© 2015 WA Exam Papers. Trinity College has a non-exclusive licence to copy and communicate this paper for non-commercial, educational use within the school. No other copying, communication or use is permitted without the express written permission of WA Exam Papers.